

Line of Sight Infrared Hydrocarbon Gas Detector Model LS2000

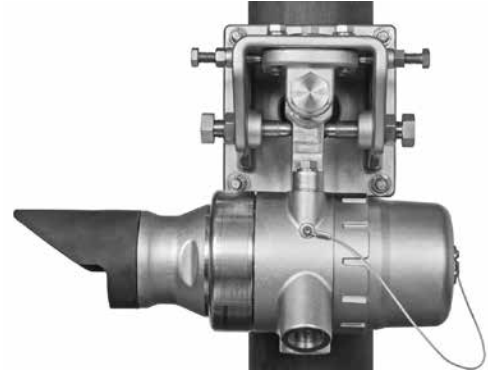

DESCRIPTION

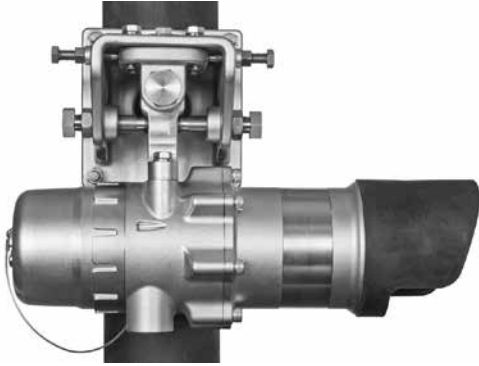

The Model LS2000 is a line of sight infrared gas detection system that provides continuous monitoring of combustible hydrocarbon gas concentrations in the range of 0 to 5 LFL-meters, over a distance of 5 to 120 meters. Standard system outputs include an electrically isolated/non-isolated 4-20 mA dc current output, with

HART communication and RS-485 MODBUS communication. Alarm and fault relays are available as an option.

The system consists of two stainless steel modules — a transmitter and a receiver, along with mounting fixture hardware. Both modules are powered from an external 24 volt DC supply. The receiver provides the measurement signal outputs, and is furnished with onboard “status indication” LEDs and an internal magnetic calibration switch. The transmitter houses a high quality xenon flash lamp.

The LS2000 is certified explosion-proof for use in Class I, Division 1 and Division 2 hazardous areas, and holds third party performance certification for methane gas detection. Propane and butane detection are also available (Det-Tronics verified). It can be used as a stand-alone detector, or as part of a larger facility protection system using other Det-Tronics equipment.

By connecting the transmitter and receiver via a three-wire shielded cable, an optional “communication link” can be created between the two devices to enable: single point system diagnostics, dynamic lamp power optimization, synchronized LEDs, transmitter configuration via connection to the receiver, and calibration initiation from either device.

FEATURES AND BENEFITS

- ▲ ± 0.8 degree misalignment tolerance (~±56cm @ 40m; ~±168cm @ 120m)
- ▲ IR source: High performance, long lasting xenon flashlamp - 10 year warranty on IR source
- ▲ Large detection coverage area (detection range 5-120 meters)
- ▲ Maximum distances and proper operation verified with 95% signal obscuration
- ▲ Compliance to FM6325 and ISA-12.13.04 performance standards
- ▲ Certified SIL 2 capable
- ▲ Third party performance certified and factory calibrated to Methane
- ▲ Propane and Butane detection performance Det-Tronics verified
- ▲ Microprocessor controlled heated optics for increased resistance to moisture and ice.
- ▲ Standard 4-20 mA output (configurable), HART communication, RS-485 Modbus
- ▲ Optional alarm relays (Ex d only)
- ▲ Mounting hardware and alignment brackets included
- ▲ Mounts to pole (4.5” nominal OD) or flat surface
- ▲ Built-in locking adjusters deliver fine control of alignment angles
- ▲ Telescope is the only tool needed for optimal alignment
- ▲ Multi-color LEDs are provided on both modules for detailed visual indication of operating status.
- ▲ Non-intrusive zero calibration options: on-board magnetic switch, MODBUS communication, HART communication, or external switch
- ▲ Optional 475 field communicator unit for communication, diagnostic, and set up from point to point
- ▲ Modular design for ease of maintenance

SPECIFICATIONS

Operating Voltage (Both Modules) 24 Vdc nominal. Operating range is 18 to 30 Vdc. Ripple cannot exceed 0.5 volts P-P.

Power Consumption

Power Consumption (Watts)			
		TX Max	RX Max
@ 24VDC	Total Unit, No Heaters or Relays	6.5	2.6
	30% Heater Only	1.4	1.1
	50% Heater Only	2.5	2.0
	70% Heater Only	3.5	2.7
	100% Heater Only	4.2	3.3
	Relay Only	N/A	1.2
Total Unit, Max		10.7	7.2
@ 33VDC*		Total Unit, Max	16.0 10.0

*Per regulatory approval requirements, the unit power consumption was measured at 33 VDC input voltage (10% above claimed range) and results listed on the product label.

Transmitter Lamp Xenon flashlamp, field-replaceable module.

Warmup Time 15 seconds minimum, 150 seconds maximum from power-up, depending upon alignment accuracy.

Current Output Linear 0-20 mA (isolated/non-isolated) rated at 600 ohms maximum loop resistance @ 24 Vdc operating voltage. Levels below 4 mA indicate a fault condition. Fault output levels are user configurable.

Relay Outputs (Optional) Available on Ex d approved models only. Two alarm, one fault relay. Form C Type (NO/NC). Contact Rating: 3 amperes at 30 VDC.

Alarm Relay Setpoint Range Low Alarm: 0.5 to 4.5 LFL-meters (default = 1)
High Alarm: 0.5 to 4.5 LFL-meters (default = 3).

Visual Status Indicator Multi-color LED on each module indicates operating status.

Available Gases Third party performance approved to methane. Det-Tronics verified propane and butane settings available.

Detection Range Short Range: 5-60 meters.
Long Range: 30-120 meters.

Misalignment Tolerance ±0.8 degree minimum (~±56cm @ 40m; ~±168cm @ 120m).

Calibration LS2000 systems are span calibrated for methane, propane, or butane at the factory. Span calibration in the field is not required.

Zero calibration can be accomplished in the field using the on-board magnetic reed switch.

Response Time T90: 2 seconds (5.0 LFL-meters applied).

Accuracy/Linearity ±5% of full scale gas concentration or ±10% of applied gas concentration, whichever is greater.

Repeatability ±5%.

Temperature Range Operating: -55°C to +75°C (-67°F to +167°F)
Storage: -55°C to +85°C (-67°F to +185°F).

Humidity 5 to 99% relative humidity; designed for outdoor applications.

Fog Performance FM 6325 performance req. 4.18

Vibration FM6325 and DNV Standard for Cert No. 2.4, Type B (DNV testing includes operation of alignment mounts during 4G vibration).

Measurement Range 0-5 LFL-meters.

Interference Resistance Immune to sun and flare radiation, tested to 800 ±50 W/m² at ≥ 3° to optical axis and common contaminants.

Self-Diagnostic Test Fail-Safe operation ensured by performing all critical tests once per second.

Module Housing Material 316 stainless steel (CF8M).

Conduit Entry Options 3/4 inch NPT or 25mm, with two entries for transmitter and four entries for receiver.

Optics Protection Microprocessor controlled heated optics mitigate against ice and dew formation.

Ingress Protection IP66/67; NEMA Type 4X

Tropicalization / PCB Protection Conformal coated printed circuit boards: CTI Rating of 600V, maximum allowed by standard. Third party tested per ASTM-D-3638-07.

Wiring Field wiring screw terminals are UL/CSA rated for up to 14 AWG shielded wire, and are DIN/VDE rated for 2.5 mm² wire.

Shipping Weight Transmitter and receiver with mounting hardware: 85 pounds (38 kg).

Warranty 5 year limited warranty from date of manufacture. 10 year warranty on IR source.

Certification **FM & CSA**
Detector with Relays:
Class I, Div. 1, Groups B, C & D (T4).
Class I, Div. 2, Groups A, B, C & D (T4).
T_{amb} = -55°C to +65°C.
NEMA Type 4X.

Detector without Relays:
Class I, Div. 1, Groups B, C & D (T4).
Class I, Div. 2, Groups A, B, C & D (T3C).
T_{amb} = -55°C to +75°C.
NEMA Type 4X.

SIL Approval
IEC 61508: 2010 Parts 1-7
Certified SIL 2 Capable.

ATEX and IECEx certification activities are currently in process.



Specifications subject to change without notice.

All trademarks are the property of their respective owners.
© 2015 Detector Electronics Corporation. All rights reserved.



Corporate Office
6901 West 110th Street | Minneapolis, MN 55438 USA
Operator: 952.941.5665 or 800.468.3244
Customer Service: 952.946.6491 or 800.765.3473
www.det-tronics.com | Email: det-tronics@det-tronics.com