

Electrochemical Toxic Gas Detector GT3000 Series Includes Transmitter (GTX) and Sensor Module (GTS)



DESCRIPTION

The Det-Tronics GT3000 line of electrochemical gas detectors is designed to provide continuous monitoring of the atmosphere for potentially hazardous gas leaks or oxygen depletion. Models are available for detecting a variety of gas types in various concentration ranges.

The GT3000 toxic gas detector is a two-wire loop powered device and is designed as a stand alone unit that supports local calibration. It is also fully compatible with the FlexVu® UD10/UD20 Universal Display Unit.

The GT3000 consists of a replaceable sensor module (GTS) connected to a transmitter module (GTX). The transmitter generates a 4-20 mA output signal with HART, which is proportional to the concentration of the target gas and directly corresponds to 0-100% full scale.

The electrochemical sensor cell uses capillary diffusion barrier technology for monitoring gas concentrations in ambient air. When compared to solid state type sensors, the electrochemical sensing element provides improved accuracy, stability and reliability, and can also extend calibration intervals. This results in superior performance and reliability, as well as reduced maintenance.

FEATURES AND BENEFITS

- Performance approved and verified
- Electrochemical sensor cell for increased accuracy, stability, and reliability
- Highly specific response reduces the chance of false alarms resulting from the presence of other gases
- Self-contained transmitter circuitry
- Temperature compensated to ensure consistent performance over entire operating temperature range
- Suitable for outdoor applications requiring IP66 rating
- Hydrophobic filter easily replaced without opening the device or use of tools
- Hot swappable IS sensor module for live maintenance without de-classification of hazardous area
- EMI/RFI hardened
- Event and calibration logs are stored in non-volatile memory and are accessible using a UD10/UD20, HART device, or AMS software.
- Real-time clock with battery back-up
- Magnetic switch and LEDs for user interface

SPECIFICATIONS

Calibration	Sensors are calibrated at the factory. Gas type and range are read by the transmitter. Calibration is initiated at the detector, at the UD10/UD20 Universal Display Unit, or by some other HART interface device.
Operating Voltage	24 Vdc nominal; Operating range is 12 to 30 Vdc.
Power Consumption	0.8 watt maximum @ 30 Vdc.
Maximum Loop Resistance	300 ohms at 18 Vdc, 600 ohms at 24 Vdc.
Current Output	4-20 mA (Normal operating mode) 3.8 mA indicates calibrate mode 3.6 mA or less indicates a fault condition.
Wiring	2x22 AWG, 1x16 AWG, 600V, 20".
Storage Temperature (Transmitter)	-55°C to +75°C (-67°F to +167°F).
Storage Temperature (Sensor)	0°C to +20°C (+32°F to +68°F) Ideal: +3°C to +9°C (+37°F to +48°F).
Humidity Range	15 to 90% RH.
Pressure Range	Atmospheric ±10%.
Warm-Up	Warm-up time can last up to 150 seconds.
Thread Options	3/4" NPT or M25.
Enclosure Material	GTX Transmitter: 316 Stainless Steel GTS Sensor Module: PPA (30% Carbon filled).
Warranty	12 months from date of installation or 18 months from date of shipment, whichever occurs first.

Certification



Explosion-Proof Model

Class I, Div. 1, Groups B, C & D (T4).
Class I, Div. 2, Groups B, C & D (T4).
IP66.
Conduit seal not required.
Acidic atmospheres excluded.

Intrinsically Safe Model

Class I, Div. 1, Groups A, B, C & D (T4).
IP66.
Conduit seal not required.

Ordering Information

Sensor module and Transmitter module must be ordered separately.

GTS Sensor Module: Specify type of gas to be detected and operating range (where applicable)

GTX Transmitter: Specify thread type (3/4 inch NPT or M25).

Dimensions

Dimensions shown in inches (centimeters).

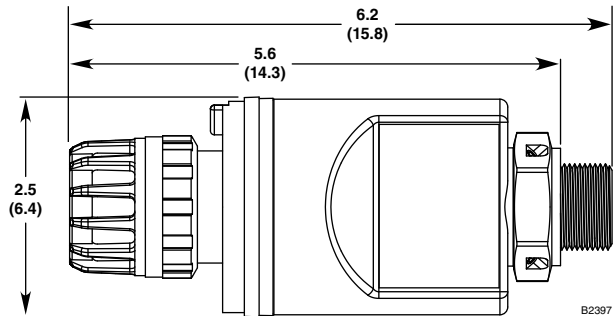

Comparison of Electrochemical Gas Sensors

Gas	Range	Response Time*	Accuracy of Reading	Operating Temperature Range	Zero Drift	Performance Tested To
Hydrogen Sulfide (H ₂ S)	0-50 PPM	T50 = 10 Sec. T90 = 23 Sec.	±2 ppm or ±10% of Reading	-40°C to +50°C	± 1 ppm/Mo.	ISA 92.0.01
Hydrogen Sulfide (H ₂ S)	0-100 PPM	T50 = 12 Sec. T90 = 28 Sec.	±2 ppm or ±10% of Reading	-40°C to +50°C	± 2 ppm/Mo.	ISA 92.0.01
Ammonia (NH ₃)	0-100 PPM**	T50 = 24 Sec. T90 = 65 Sec.	±4 ppm or ±10% of Reading	-20°C to +40°C	± 2 ppm/Mo.	FM6340
Oxygen (O ₂)	0-25%***	T20 = 7 Sec. T90 = 30 Sec.	< 0.5% V/V	-20°C to +50°C	< 2 %/Mo.	BS EN 50104
Carbon Monoxide (CO)	0-500 PPM	T50 = 12 Sec. T90 = 25 Sec.	±5 ppm or ±10% of Reading	-20°C to +50°C	± 9 ppm/Mo.	ISA 92.02.01
Sulfur Dioxide (SO ₂)	0-20 PPM	T50 = 12 Sec. T90 = 30 Sec.	±0.8 ppm or ±10% of Reading	-20°C to +50°C	± 0.4 ppm/Mo.	ISA 92.00.01
Chlorine Cl ₂	1-10 PPM	T50 = ≤14 Sec. T90 = ≤34 Sec.	±0.6 ppm or ±10% of Reading	-20°C to +50°C	< 0.2 ppm/Mo.	FM6340

* Time to reach percentage of final reading when gas concentration equal to full scale is applied to sensor.

** Background concentrations of ammonia may shorten lifetime of sensor.

*** Sensor approved for oxygen depletion only.

George R. Peters Associates ENGINEERING SALES REPRESENTATIVES

650 E. Big Beaver • Suite C • Troy, MI 48083
(248) 524-2211 • Fax (248) 524-1758
www.grpeters.com

Specifications subject to change without notice.

Det-Tronics, the DET-TRONICS logo, and FlexVu are registered trademarks or trademarks of Detector Electronics Corporation in the United States, other countries, or both. Other company, product, or service names may be trademarks or service marks of others.

©Copyright Detector Electronics Corporation 2009. All rights reserved.



Detector Electronics Corporation

6901 West 110th Street • Minneapolis, Minnesota 55438 USA
Operator: (952) 941-5665 or (800) 765-FIRE
Customer Service: (952) 946-6491 • Fax (952) 829-8750
http://www.det-tronics.com • E-mail: det-tronics@det-tronics.com